

# ELECON **SUPER SERIES** IN WORM GEAR UNITS

Super **NU** Series

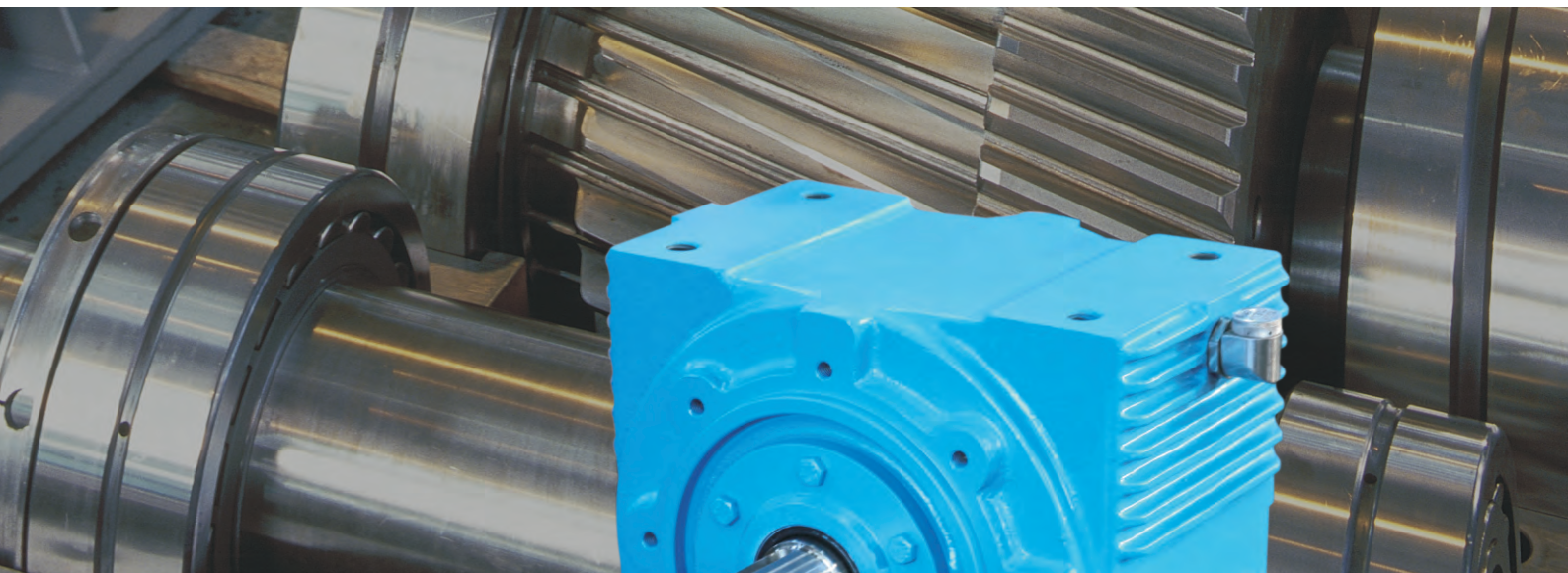

**SIZE: 4" to 10.5"**

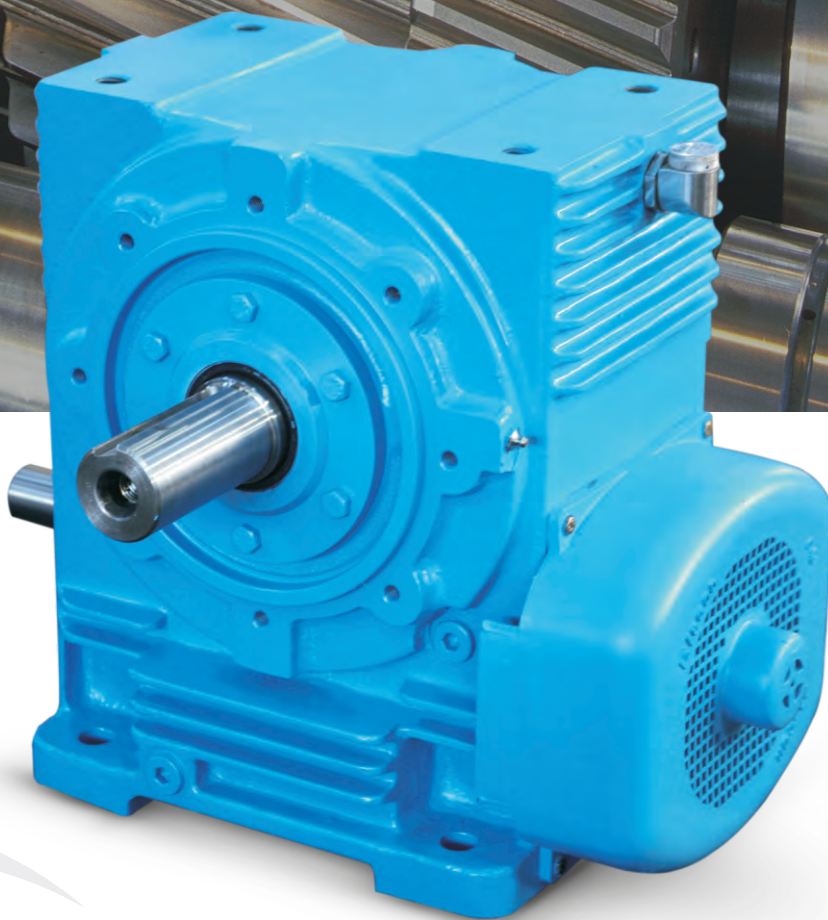

www.elecon.com

 **ELECON**  
GEARING THE FUTURE

# 4 TO 10.5 SNU

## SNU-U

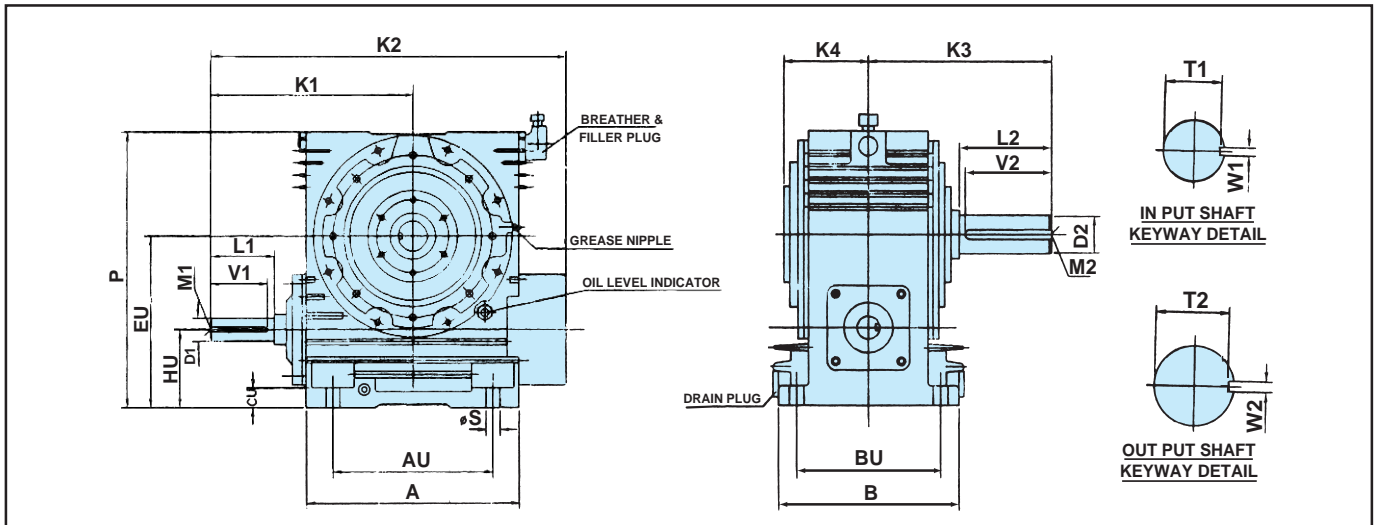

SIZE	A	AU	B	BU	CU	φS	HU	EU	P	D1	L1	V1	M1	T1	W1	K1	K2	D2	L2	V2	M2	T2	W2	K3	K4
4 SNU-U	250	180	200	160	25	18	108	209.6	325	32	65	60	M12	27	10	215	440	45	90	85	M16	39.5	14	215	115
5 SNU-U	300	220	252	200	30	18	118	245	385	35	70	65	M12	30	10	242	492	50	100	95	M16	44.5	14	235	130
6 SNU-U	354	266	302	241	32	23	127	279.4	450	38	75	70	M12	33	10	279	580	58	114	111	M20	52	16	274	155
7 SNU-U	400	306	340	265	36	23	146	323.8	524	40	82	79	M16	35	12	311	656	65	130	127	M20	58	18	287	160
8 SNU-U	440	343	340	265	40	27	146	349.2	574	45	88	85	M16	39.5	14	342	710	70	140	137	M20	62.5	20	312	175
9 SNU-U	490	390	344	282	40	27	154	382.6	635	50	95	92	M16	44.5	14	375	776	75	145	140	M20	67.5	20	325	180
10.5 SNU-U	590	432	430	330	50	33	172	438.7	720	60	115	110	M20	53	18	450	925	80	150	147	M20	71	22	352	200

## SNU-O

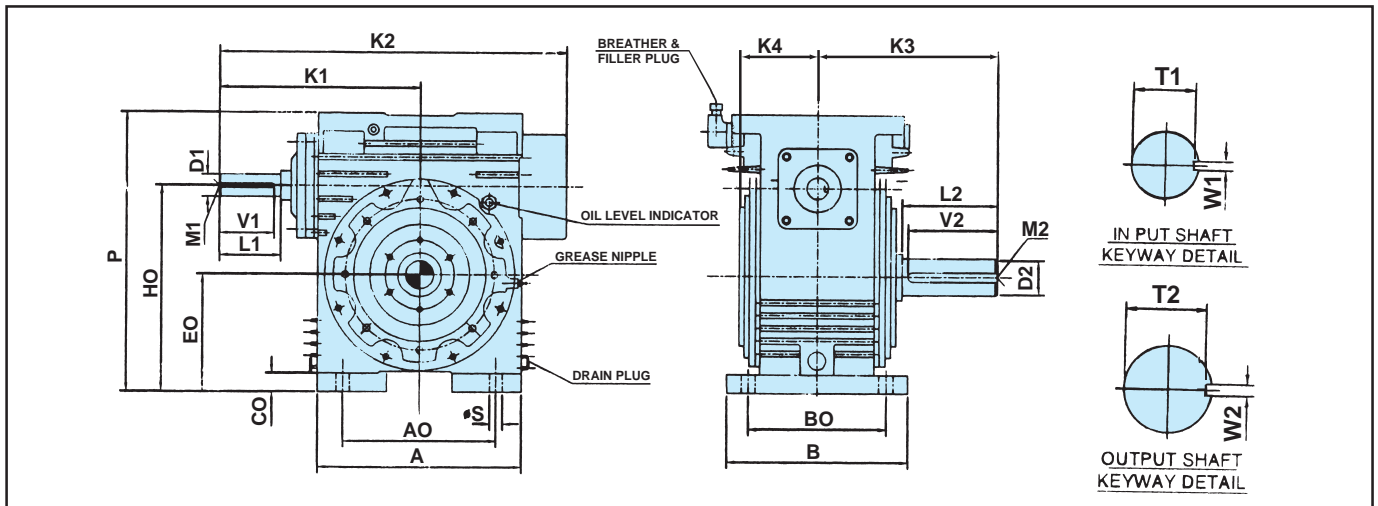

SIZE	A	AO	B	BO	CO	φS	HO	EO	P	D1	L1	V1	M1	T1	W1	K1	K2	D2	L2	V2	M2	T2	W2	K3	k4
4 SNU-O	250	180	240	200	25	18	241.6	140	350	32	65	60	M12	27	10	215	440	45	90	85	M16	39.5	14	215	115
5 SNU-O	300	220	270	230	25	18	292	165	410	35	70	65	M12	30	10	242	492	50	100	95	M16	44.5	14	235	130
6 SNU-O	354	266	310	250	30	23	352.4	200	479.4	38	75	70	M12	33	10	279	580	58	114	111	M20	52	16	274	155
7 SNU-O	400	306	340	266	44	23	421.8	244	568	40	82	79	M16	35	12	311	656	65	130	127	M20	58	18	287	160
8 SNU-O	440	343	340	266	44	27	472.2	269	618	45	88	85	M16	39.5	14	342	656	70	140	137	M20	62.5	20	312	175
9 SNU-O	490	390	414	340	44	27	524.6	296	679	50	95	92	M16	44.5	14	375	776	75	145	140	M20	67.5	20	325	180
10.5 SNU-O	590	432	484	400	50	33	597.7	331	770	60	115	110	M20	53	18	450	925	80	150	147	M20	71	22	352	200

Key & Keyways as per IS 2048. Shaft limits up to 58dia.-k6 and above 58 dia.-m6

# SNU-V

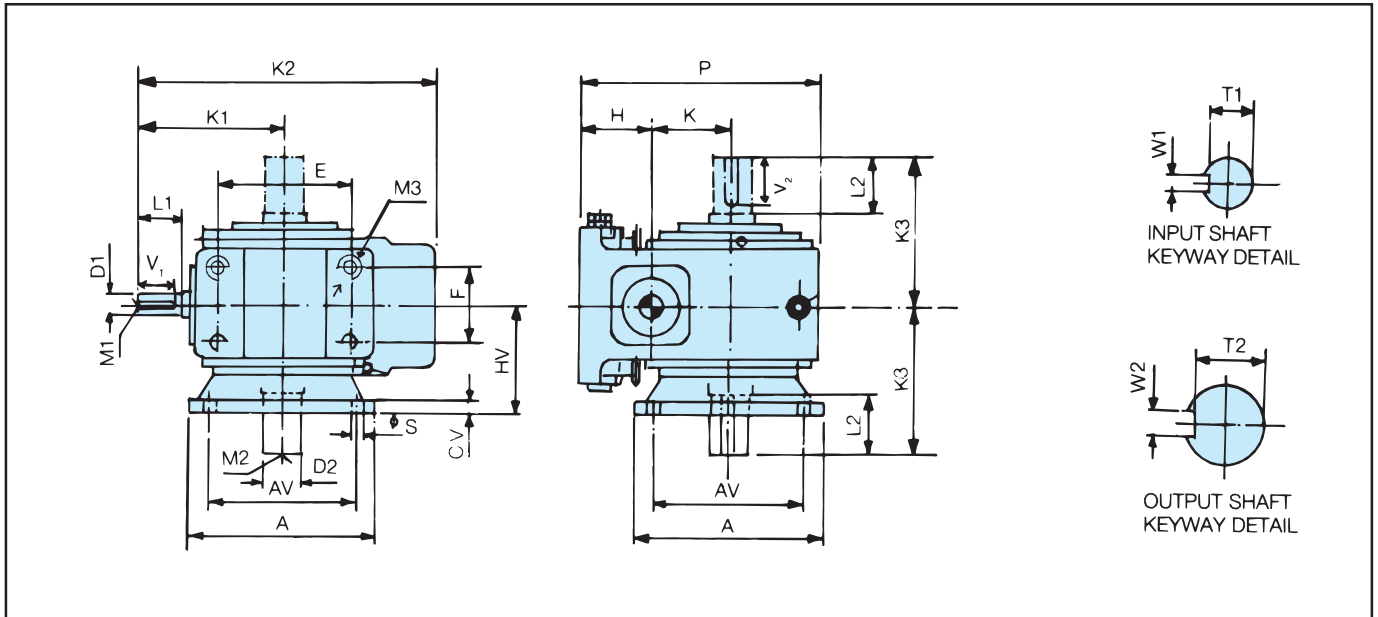

Size	A	AV	CV	φS	HV	H	K	P	D1	L1	V1	M1	T1	W1	K1	K2	D2	L2	V2	M2	T2	W2	K3	E	F	M3
4 SNU-V	280	235	20	18	140	108	101.6	325	32	65	60	M12	27	10	215	440	45	90	85	M16	39.5	14	215	200	100	M16
5 SNU-V	320	260	22	18	165	118	127	385	35	70	65	M12	30	10	242	492	50	100	95	M16	44.5	14	235	240	130	M16
6 SNU-V	340	270	25	23	180	127	152.4	450	38	75	70	M12	33	10	279	580	58	114	111	M20	52	16	274	280	150	M20
7 SNU-V	400	320	40	27	200	146	177.8	524	40	82	79	M16	35	12	311	656	65	130	127	M20	58	18	287	320	150	M20
8 SNU-V	440	360	40	27	220	146	203.2	574	45	88	85	M16	39.5	14	342	710	70	140	137	M20	62.5	18	312	340	180	M24
9 SNU-V	490	410	40	27	240	154	228.6	635	50	95	92	M16	44.5	14	375	776	75	145	140	M20	67.5	20	325	386	180	M24
10.5 SNU-V	560	460	40	33	260	172	266.7	720	60	115	110	M20	53	18	450	925	80	150	147	M20	71	22	352	440	220	M30

# SNU-SM SHAFT MOUNTED WORM GEAR UNIT

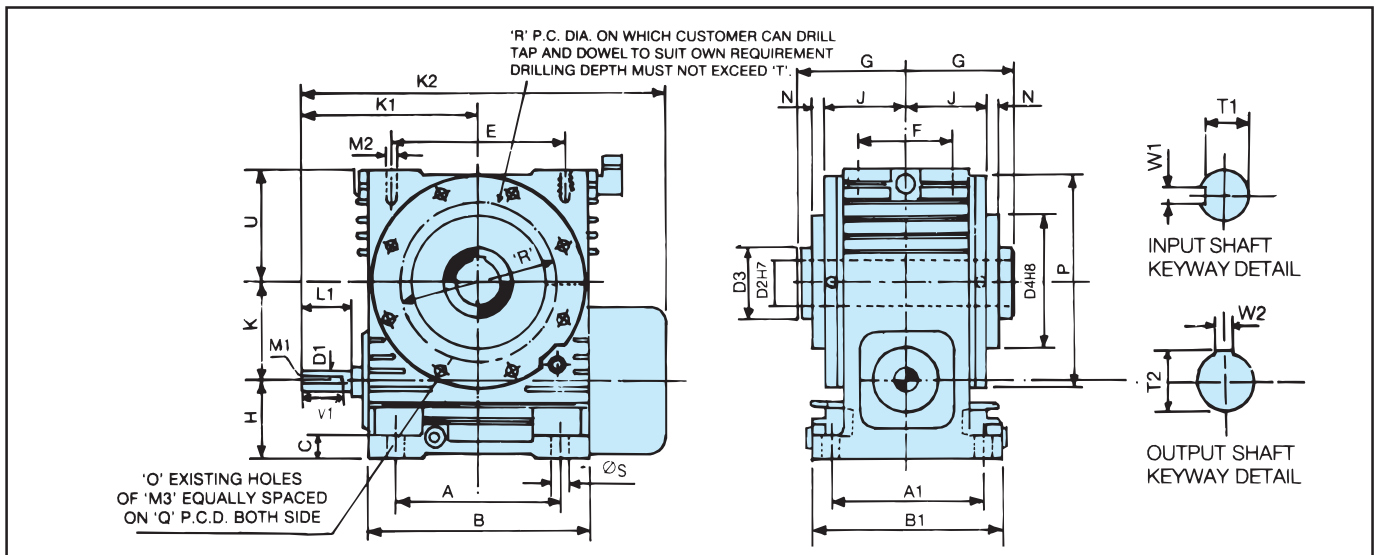

SIZE	K	H	U	K1	K2	G	J	N	D1	L1	V1	M1	T1	W1	D2	T2	W2	D3	D4	P	A	A1	B	B1	C	S	E	F	M2	O	Q	M3	R	T
4 SNU-SM	101.6	108	115	215	440	115	95	6	32	65	60	M12	27	10	65	69.4	18	95	146	222	180	160	250	200	25	18	200	100	M16	8	200	M8	165	20
5 SNU-SM	127	118	140	242	492	145	115	15	35	70	65	M12	30	10	70	75.1	20	105	195	272	220	200	300	252	30	18	240	130	M16	8	250	M10	210	20
6 SNU-SM	152.4	127	170	279	580	165	132	20	38	75	70	M12	33	10	75	80.1	20	105	205	330	266	241	354	302	32	23	280	150	M20	8	305	M10	250	20
7 SNU-SM	177.8	146	200	311	656	160	132	8	40	82	79	M16	35	12	80	85.6	22	120	224	390	306	266	400	340	36	23	320	150	M20	12	355	M10	280	20
8 SNU-SM	203.2	146	225	342	710	180	148	8	45	88	85	M16	39.5	14	90	95.6	25	130	263	445	343	266	440	340	40	27	340	160	M24	12	405	M12	318	20
9 SNU-SM	228.6	154	252.4	375	776	190	157	8	50	95	92	M16	44.5	14	95	100.6	25	140	266	492	390	282	490	344	40	27	386	180	M24	12	460	M12	330	20
10.5 SNU-SM	266.7	172	281.3	450	925	205	180	8	60	115	110	M20	53	18	100	106.6	28	152	292	540	432	330	590	430	50	33	440	220	M30	12	510	M12	380	20

Key & Keyways as per IS 2048. Shaft limits up to 58dia.-k6 and above 58 dia.-m6

### RATINGS AT INPUT SPEED 1500 R.P.M.

GEAR RATIO	OUTPUT SPEED R.P.M.	CAPACITY	SIZE OF UNIT						
			4	5	6	7	8	9	10.5
5	300	INPUT POWER KW	14.1	23.5	41	55	72	82.4	139.3
		OUTPUT TORQUE Nm	420.1	710.6	1253	1646.6	2177.4	2491.2	4260.2
7.5	200	INPUT POWER KW	10	18.2	27	43.2	58	63.4	94
		OUTPUT TORQUE Nm	444.1	820	1211.9	1935	2603	2933.2	4309
10	150	INPUT POWER KW	8.5	16.5	24	33.1	46	74.5	84
		OUTPUT TORQUE Nm	503.3	966.5	1444	1952.3	2753	4506	4920.2
15	100	INPUT POWER KW	7	12	21.5	30	40	56	63
		OUTPUT TORQUE Nm	568.2	986	1827.4	2580	3514.4	5027	5535.2
20	75	INPUT POWER KW	6.1	11.5	16.2	25.8	31.2	48	55.2
		OUTPUT TORQUE Nm	652.8	1205.2	1836.8	2814	3496.1	5447.3	6393.2
25	60	INPUT POWER Kw	5	9	13	20	28	42	48
		OUTPUT TORQUE Nm	684.4	1218.3	1810.5	2706	3788.2	6061.5	6723.2
30	50	INPUT POWER KW	4.5	7.5	12.2	17	23	40	42
		OUTPUT TORQUE Nm	747.8	1217.6	1980.7	2760	3778	6876	7059.3
40	37.5	INPUT POWER KW	3.8	5.8	10.4	15	20	32	36
		OUTPUT TORQUE Nm	754.8	1168	2118.8	3132.4	4278.4	7253	7793
50	30	INPUT POWER KW	3	5	8.5	13	17	27	32
		OUTPUT TORQUE Nm	764	1257.4	2088.4	3228	4437.5	7220	8455
60	25	INPUT POWER KW	2.6	4.2	7	11	14	22	27.4
		OUTPUT TORQUE Nm	739.9	1171.2	2032.2	3193.5	4011	6597	8373
70	21.4	INPUT POWER KW	32.3	3.6	5.8	8.5	11.3	19	24.5
		OUTPUT TORQUE Nm	759.5	1124.6	1811.8	2769.1	3782	6868	8528

### RATINGS AT INPUT SPEED 1000 R.P.M.

GEAR RATIO	OUTPUT SPEED R.P.M.	CAPACITY	SIZE OF UNIT						
			4	5	6	7	8	9	10.5
5	200	INPUT POWER KW	12.2	22.2	32.2	346.5	59.1	64.4	112.8
		OUTPUT TORQUE Nm	553.4	1022.9	1462	2087.2	2717.6	2912	5143.8
7.5	133	INPUT POWER KW	9.04	17	25	37	47.46	54.1	83
		OUTPUT TORQUE Nm	610.2	1147.4	1687.4	2497.4	3254.5	3682.1	5649
10	100	INPUT POWER KW	7.8	14.59	22.4	28.24	38.5	48.5	57.3
		OUTPUT TORQUE Nm	692.8	1295.8	2010.8	2481.2	3492.9	4400	5143.8
15	66.7	INPUT POWER KW	6.5	9.3	16.5	24.2	29.5	37.3	50
		OUTPUT TORQUE Nm	856.2	1225	2197.1	3187.7	3928.1	4966	6657.8
20	50	INPUT POWER KW	6.2	8.8	13	17.5	24.2	30.8	44.5
		OUTPUT TORQUE Nm	1065.8	1462.3	2185	2874.6	3882.6	5471	7649.5
25	40	INPUT POWER KW	5	7.1	10.2	15.6	21	27	36
		OUTPUT TORQUE Nm	1026.6	1440.9	2094.3	3203.1	4412.1	5673	7735.5
30	33.4	INPUT POWER KW	4.2	6.2	9	14.23	18.8	23.2	31
		OUTPUT TORQUE Nm	1008.8	1524.6	2187.4	3417.8	4569.1	5722	7828.5
40	25	INPUT POWER KW	3.7	24.9	7.8	11	14.5	20	28.7
		OUTPUT TORQUE Nm	1122.6	1516.2	2383.7	3445.6	4542	6417	8770.1
50	20	INPUT POWER KW	2.6	4.2	6.6	9.6	13	15.4	21.6
		OUTPUT TORQUE Nm	918.7	1544.2	2426.7	3529.7	4966	5956.3	8302.7
60	16.7	INPUT POWER KW	2.22	3.6	5.4	8.2	11	13.1	19
		OUTPUT TORQUE Nm	939.4	1482.3	2254.3	3423.1	4717.8	5993	8475
70	14.3	INPUT POWER KW	2.16	3.13	4.6	6.9	8.88	10.1	15.8
		OUTPUT TORQUE Nm	980.9	1463.2	2089	3317.8	4210.5	5961.2	8125

- The Ratings are based on service factor of 1, continuously transmitted for 12 hours/day with normal overload of 100% momentarily for 15 seconds, 40% for 30 minutes, 25% for 2 hours.
- For Ratings at other Input speed please consult ELECON.

## ACTUAL GEAR RATIO

SIZE OF UNIT	NOMINAL RATIO										
	5	7.5	10	15	20	25	30	40	50	60	70
4	4.83	7.24	9.67	14.5	19.5	25	30	40	50	60	71
5	4.83	7.25	9.67	14.5	19.5	25	30	40	50	60	71
6	4.86	7.25	9.67	14.5	19.5	25	30	40	50	60	70
7	5.14	7.25	9.67	14.67	19.5	24.5	30	40	50	60	71
8	5.14	7.20	9.75	14.67	19.5	24.5	30	40	50	60	71
9	5.14	7.20	9.75	14.67	19.5	24.5	30	40	50	60	71
10.5	4.85	7.33	9.75	14.67	19.5	24.5	29.5	40	50	60	70

### OVERHUNG LOADS :

Whenever a sprocket, gear, sheave or pulley is mounted on the output shaft, a calculation should be made to determine the overhung load in Newtons on the shaft, using the formula :

$$P = \frac{KW \times 9550 \times K}{N \times R}$$

Where, P = equivalent overhung load in Newtons  
 KW = power carried by shaft in Kilo Watts  
 N = r.p.m. of the shaft  
 R = pitch radius of sprocket, pinion, sheave or pulley in meter  
 K = factor

Overhung Member	K Factor
Sprocket	1.00
Spur Pinion	1.25
V-belt Sheave	1.50
Flat Belt Pulley	2.00

The calculated equivalent overhung load should be compared with the permissible values given in the table.

### Maximum permissible overhung loads (Newtons) at centre of wheel shaft extension at 1500 r.p.m. Input Speed.

RATIO	BEARING NEAR SHAFT EXTENTION	SIZE OF UNIT						
		4	5	6	7	8	9	10.5
5	STD TRB	10454	12180	13636	15818	15900	16800	19800
	STD TRB+CRB	11720	15800	20963	22230	24225	24335	29865
7.5	STD TRB	11400	15090	16910	18900	19363	20010	22820
	STD TRB+CRB	13300	17600	24280	23450	26035	27110	33340
10	STD TRB	11120	16000	17636	19350	22335	22860	26325
	STD TRB+CRB	15593	19500	25450	25630	31400	32000	33495
15	STD TRB	10100	16620	17834	22300	24090	24000	28300
	STD TRB+CRB	16600*	20110*	26575*	27780*	32800	33000	41000
20	STD TRB	10252	15300	18014	23000	23800	26840	27715
	STD TRB+CRB	17481*	22800*	27220*	27980*	34600*	44825*	44815*
25	STD TRB	10468	15545	18443	22250	24604	28600	28900
	STD TRB+CRB	17481*	24700*	27280*	29423*	35988*	47300*	48800*
30	STD TRB	11061	15000	19816	21386	25520	30800	29120
	STD TRB+CRB	17914*	24400*	27468*	32373*	37769*	51150*	51200*
40	STD TRB	12194	16618	22170	24035	29675	34650	35325
	STD TRB+CRB	18990*	25575*	30411*	37769*	41760*	52495*	52015*
50	STD TRB	13165	17805	24133	25506	31078	36740	33325
	STD TRB+CRB	20126*	27366*	34335*	39710*	43812*	53000*	53800*
60	STD TRB	13813	18830	25133	26880	32481	31195	31800
	STD TRB+CRB	20880*	29136*	37572*	42516*	45646*	53120*	54000*
70	STD TRB	14513	19747	26389	29234	34100	35320	30300
	STD TRB+CRB	21474*	30269*	38357*	43066*	47696*	54000*	57475*

\* SPECIAL HEAT - TREATED SHAFT

TRB = TAPER ROLLER BEARING  
 CRB = CYLINDRICAL ROLLER BEARING

### AVERAGE WEIGHT IN KILOGRAMS

Gear Size	4		5		6		7		8		9		10.5	
GEAR TYPE	NET	GR.	NET	GR.	NET	GR.	NET	GR.	NET	GR.	NET	GR.	NET	GR.
SNU-U	65	95	95	125	152	190	180	230	220	270	319	385	460	585
SNU-O	72	102	105	135	165	204	195	265	237	305	336	400	480	600
SNU-V	73	103	105	135	166	205	200	270	250	315	348	430	481	610
SNU-SM	64	80	110	140	157	170	200	270	252	316	330	415	465	590

### APPROXIMATE OIL CAPACITY FOR SNU GEAR UNIT IN LITRES

SNU-U	2.5	4	5	9.5	11	16	21
SNU-O	5.1	8	13.5	18	19	41	45
SNU-V	4.0	5.7	8.5	18	20	25	26

### APPROXIMATE OIL CAPACITY FOR SNU-SM GEAR UNIT FOR DIFFERENT MOUNTING POSITIONS IN LITRES

Gear Size	4	5	6	7	8	9	10.5
A	5	7	10	18	19	41	45
B	2.5	4	6	9.5	11	16	21
C	2.5	4.7	8.8	18	20	25	26
D/E	3.5	8	11.6	19	20	25	26

### RECOMMENDED LUBRICANTS

Brands	Grade
Bharat Petroleum	Cabol 320
Castrol	Alpha Zn 320 or Alpha Sp-320 or Tribol 1100/320 TGQA
Hindustan Petroleum	Enklo 320 or Parthan EP 320
Indian Oil	Servomesh SP 320 or Servosystem 320

### RECOMMENDED GREASE : FOR LOW SPEED OF OPERATION

BRAND	GRADE
Castrol	EPL 2
Indian Oil	Servogem EP 2

## PRODUCT SAFETY INFORMATION

**General** ELECON gear units will operate safely provided that they are selected, installed, used and maintained properly. As with any equipment consisting of rotating shafts and transmitting power, adequate guarding is necessary to eliminate the possibility of physical contact with rotating shafts or coupling.

**Potential Hazards** The following points should be noted and brought to attention to the persons involved in the installation, use and maintenance of equipment.

1. For lifting of gear unit eye-bolts or lifting points (on larger units) should be used.
2. Check the grade and quantity of lubrication before commissioning. Read and carry out all instructions on lubricant plate and in the installation and maintenance manual literature.
3. Installation must be performed in accordance with the manufacturer's instruction and be undertaken by suitably qualified personnel.
4. Ensure the proper maintenance of gearboxes in operation. **USE ONLY ELECON SPARES FOR GEARBOXES.**
5. The oil level should be examined periodically, if required the oil should be filled again.
6. The operating speeds, transmitting powers, generated torques or the external loads must not exceed the design values.
7. The driving and the driven equipment must be correctly selected to ensure that the complete installation of the machinery will perform satisfactorily e.g. avoiding system critical speeds, system torsional vibration etc.

**Any other required information or clarification can be obtained by writing to :**

### **ELECON ENGINEERING CO. LTD.**

POST BOX # 6, VALLABH VIDYANAGAR 388 120, GUJARAT, INDIA

TEL.: +91-2692-236513, 236520, 232890 FAX : +91-2692-236527

E-MAIL : [infogear@elecon.com](mailto:infogear@elecon.com)

Web Site : <http://www.elecon.com>

As improvement in designing are continuously being made, the details and dimensions are subject to alteration without notice.