

ELECON **SUPER SERIES** IN WORM GEAR UNITS



SIZE: 10" to 17"



www.elecon.com

Catalogue No.: 203/G/02/2011



SFU

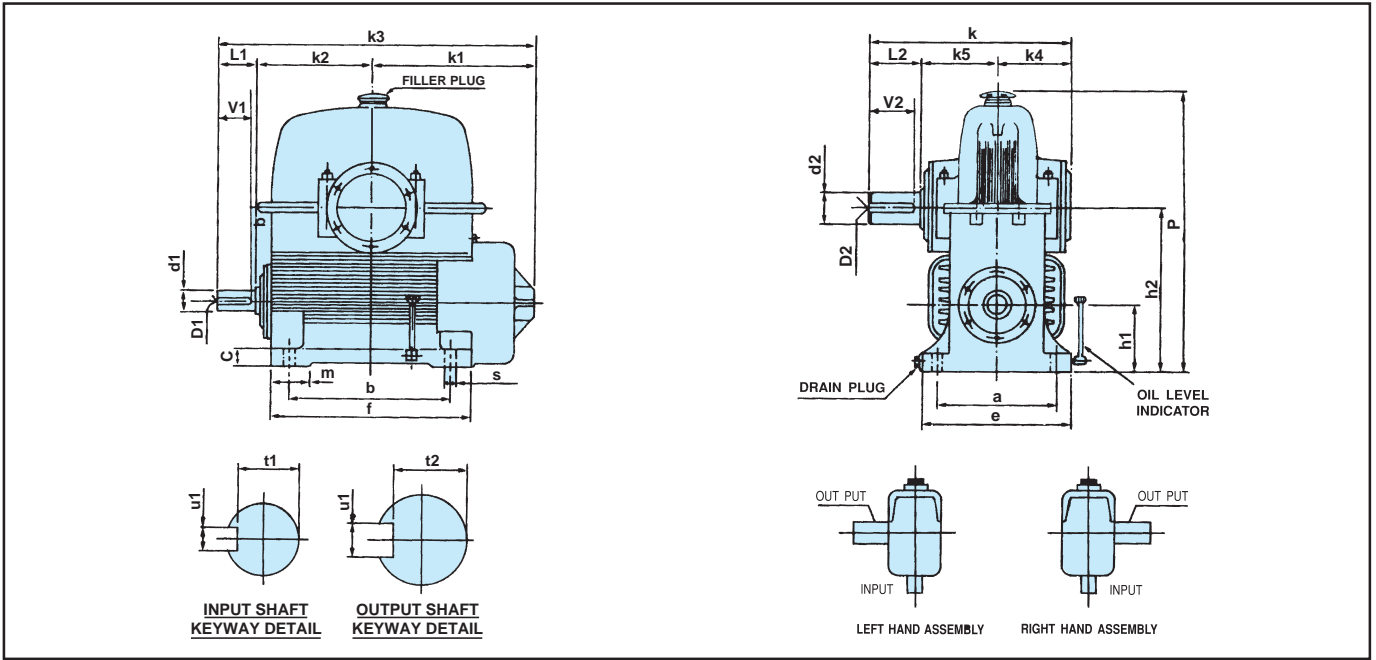

SIZE	GEARBOX MOUNTING DETAIL							CLEARANCE DIMENSIONS										SHAFT END DETAILS										
	a	b	c	e	f	m	s	h1	h2	k	k1	k2	k3	k4	k5	P	d1	L1	V1	t1	u1	D1	d2	L2	V2	t2	u2	D2
10 SFU	330	432	50	430	590	120	33	171.5	425.5	573	470	335	895	198	202	730	57	90	85	51	16	M20	82	173	170	73	22	M20
12 SFU	368	521	55	540	690	150	33	190.5	495.3	589	505	360	990	208	216	860	60	125	120	53	18	M20	85	165	160	76	22	M20
14 SFU	432	597	65	560	820	180	33	216	571.6	635	545	450	1135	215	220	970	80	140	135	71	22	M20	110	200	195	100	28	M24
17 SFU	508	762	75	600	920	170	33	254	685.8	825	650	520	1340	300	310	1185	85	170	160	78	22	M20	135	215	210	123	36	M30

SFO

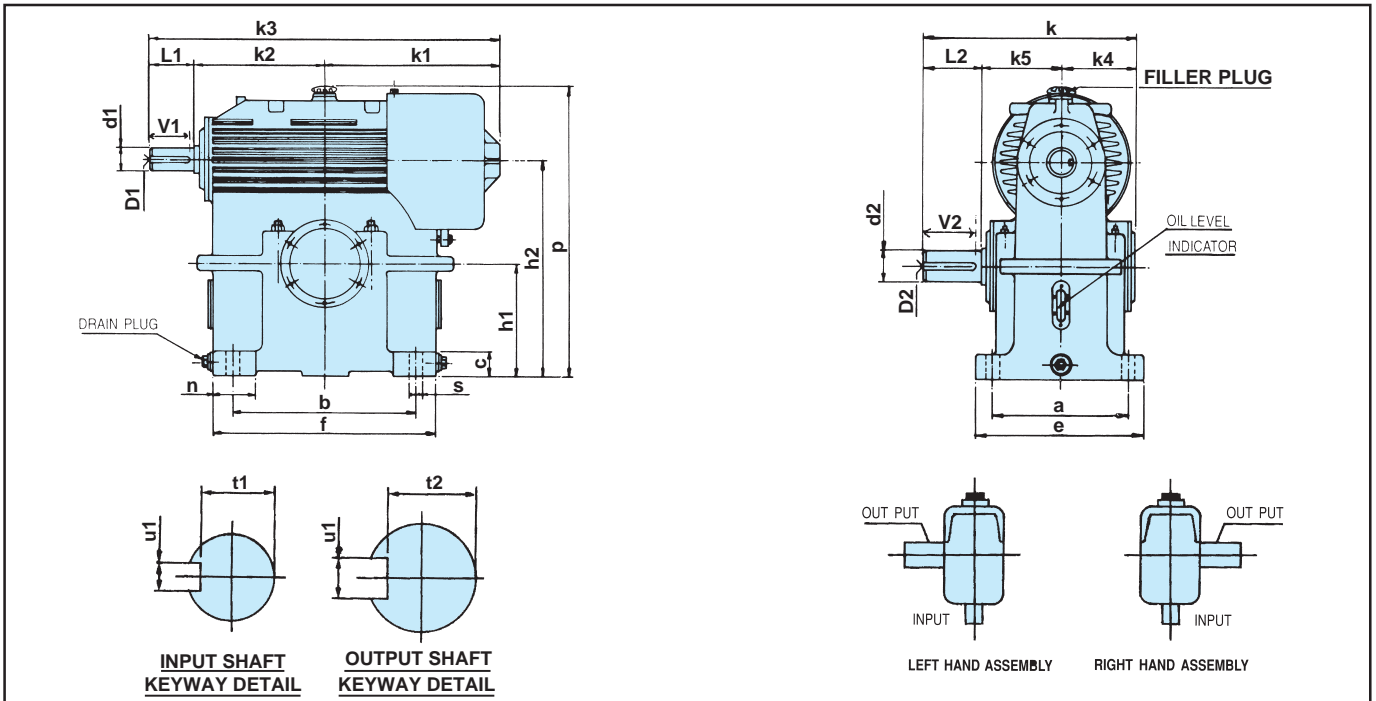

SIZE	GEARBOX MOUNTING DETAIL							CLEARANCE DIMENSIONS										SHAFT END DETAILS										
	a	b	c	e	f	m	s	h1	h2	k	k1	k2	k3	k4	k5	P	d1	L1	V1	t1	u1	D1	d2	L2	V2	t2	u2	D2
10 SFO	330	432	50	430	580	120	33	273	527	573	470	335	895	198	202	707	57	90	85	51	16	M20	82	173	170	73	22	M20
12 SFO	440	530	55	540	630	125	33	330	634.8	589	500	360	985	208	216	819	60	125	120	53	18	M20	85	165	160	76	22	M20
14 SFO	470	620	65	560	770	150	33	395	750.6	738	610	450	1200	258	280	952	80	140	135	71	22	M20	110	200	195	100	28	M24
17 SFO	510	750	75	600	920	170	33	460	891.8	825	650	520	1340	300	310	1146	85	170	160	76	22	M20	135	215	210	123	36	M30

Key & Keyways as per IS 2048. Shaft limits upto 58dia.-k6 and above 58 dia.-m6

SFV

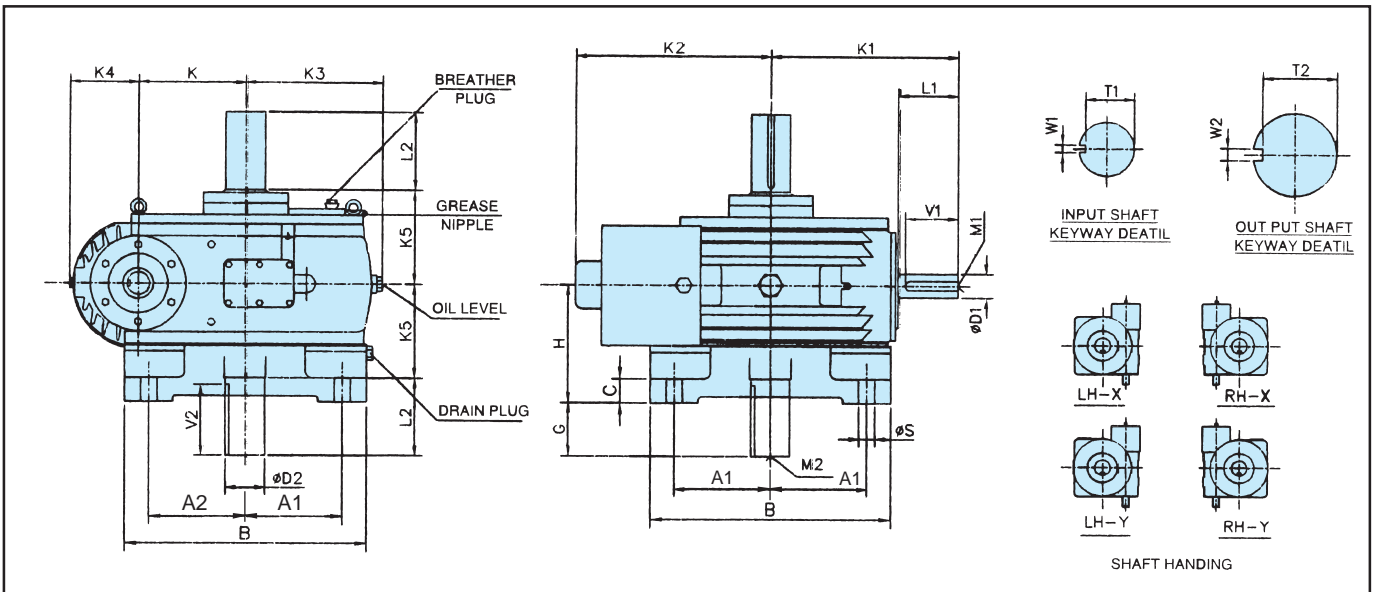

SIZE	A1	A2	B	C	ΦS	H	K1	K2	K3	K	K4	K5	G	D1	L1	V1	T1	W1	M1	D2	L2	V2	T2	W2	M2
10 SFV	260	235	620	55	33	279	425	470	300	254	180	202	96	57	90	85	51	16	M20	82	173	170	73	22	M20
12 SFV	250	250	620	60	33	280	485	500	350	304.8	175	216	101	60	125	120	53	18	M20	85	165	160	76	22	M20
14 SFV	290	290	700	65	33	300	590	545	419	355.6	200	220	120	80	140	135	71	22	M20	110	200	195	100	28	M24
17 SFV	400	400	1000	75	40	345	690	651	520	431.8	238	310	180	85	170	160	76	22	M20	135	215	210	123	36	M30

SSM

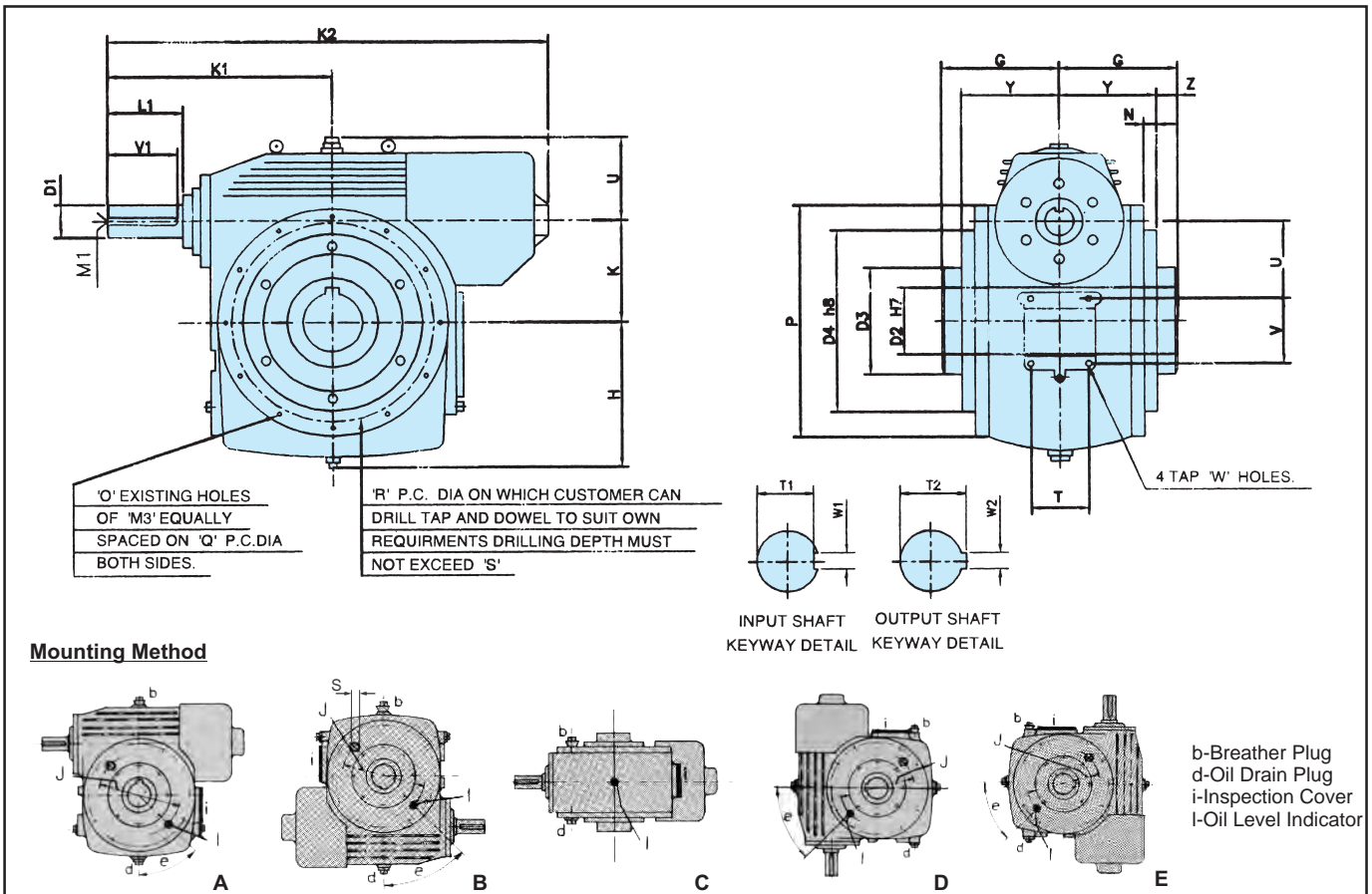

SIZE	K	H	U	K1	K2	D1	L1	V1	M1	T1	W1	D2	T2	W2	D3	D4	P	G	N	Y	Z	O	Q	M3	R	S	T	U	V	W
12 SSM	304.8	380	226	485	990	60	125	120	M20	53	18	110	116.4	28	180	360	640	220	10	200	20	12	605	M12	450	25	140	225	175	M24
14 SSM	355.6	450	250	590	1180	80	140	135	M20	71	22	140	148.4	36	185	400	770	240	10	225	15	12	720	M16	530	25	140	226	235	M24

Key & Keyways as per IS 2048. Shaft limits upto 58dia.-k6 and above 58 dia.-m6

RATINGS AT INPUT SPEED 1500 R.P.M.

GEAR RATIO	OUTPUT SPEED R.P.M.	CAPACITY	SIZE OF UNIT			
			10	12	14	17
5	300	INPUT MECH. POWER (KW)	123	196.3	274.3	*
		OUTPUT MECH. TORQUE (Nm)	3700.0	5493.6	8224.7	*
		INPUT THERMAL POWER (KW)	90	119.4	162	*
		OUTPUT THERMAL TORQUE (Nm)	2707.7	3776.85	4857	*
7.5	200	INPUT MECH. POWER (KW)	92	128	184	*
		OUTPUT MECH. TORQUE (Nm)	4129.4	5699.61	8279.6	*
		INPUT THERMAL POWER (KW)	76	108.6	150	*
		OUTPUT THERMAL TORQUE (Nm)	3411.3	4806.9	6674.7	*
10	150	INPUT MECH. POWER (KW)	65	110.5	162.4	320
		OUTPUT MECH. TORQUE (Nm)	3807.3	6557	9635.4	19354.6
		INPUT THERMAL POWER (KW)	62	98.7	141	200
		OUTPUT THERMAL TORQUE (Nm)	3631.5	6464.6	8358.1	12224
15	100	INPUT MECH. POWER (KW)	58	81	150	249
		OUTPUT MECH. TORQUE (Nm)	4985.1	7131.87	13349.4	21877
		INPUT THERMAL POWER (KW)	56	76	110	177
		OUTPUT THERMAL TORQUE (Nm)	4813.2	6670.8	9790.8	15720.5
20	75	INPUT MECH. POWER (KW)	55	75	123	216
		OUTPUT MECH. TORQUE (Nm)	6303.3	8619	14288.3	25028.6
		INPUT THERMAL POWER (KW)	48	63	94.3	160
		OUTPUT THERMAL TORQUE (Nm)	5500.8	7239.8	10954.8	18366
25	60	INPUT MECH. POWER (KW)	45	67.5	110	172
		OUTPUT MECH. TORQUE (Nm)	6303.0	9380.3	14695.4	24365.2
		INPUT THERMAL POWER (KW)	39	50	71.6	135
		OUTPUT THERMAL TORQUE (Nm)	5462.6	6948.4	9947.3	19124
30	50	INPUT MECH. POWER (KW)	40	56	92	158
		OUTPUT MECH. TORQUE (Nm)	6494.0	9339.1	14652.2	26556.6
		INPUT THERMAL POWER (KW)	32	45	61.2	121
		OUTPUT THERMAL TORQUE (Nm)	5195.2	7504.65	9761	20337
40	37.5	INPUT MECH. POWER (KW)	34	51.	76	119
		OUTPUT MECH. TORQUE (Nm)	7359.9	10830.2	16137.4	26062.6
		INPUT THERMAL POWER (KW)	25	37	48	93
		OUTPUT THERMAL TORQUE (Nm)	5411.7	7857.8	10192.6	20131.4
50	30	INPUT MECH. POWER (KW)	28	44	62	110
		OUTPUT MECH. TORQUE (Nm)	7130.7	11404.1	16457.4	29064
		INPUT THERMAL POWER (KW)	22	31	39.5	81.6
		OUTPUT THERMAL TORQUE (Nm)	5602.7	8740.7	10486.9	21300.32
60	25	INPUT MECH. POWER (KW)	24	37	54.8	78
		OUTPUT MECH. TORQUE (Nm)	7242.7	11092.2	17520.6	25326.6
		INPUT THERMAL POWER (KW)	18	28	33.6	45.2
		OUTPUT THERMAL TORQUE (Nm)	5432.0	8397.4	10702.7	17712.6
70	21.4	INPUT MECH. POWER (KW)	21	32	46	75
		OUTPUT MECH. TORQUE (Nm)	7309.8	11207	16716.2	27445
		INPUT THERMAL POWER (KW)	20	22.5	28.4	57.3
		OUTPUT THERMAL TORQUE (Nm)	6961.7	7880.4	10320.1	20456.6

- The Ratings are based on service factor of 1, continuously transmitted for 12 hours/day with normal overload of 100% momentarily for 15 seconds, 40% for 30 minutes, 25% for 2 hours.
 - For Ratings at other Input speed please consult ELECON.
- For rating marked * consult ELECON

RATINGS AT INPUT SPEED 1000 R.P.M.

GEAR RATIO	OUTPUT SPEED R.P.M.	CAPACITY	SIZE OF UNIT			
			10	12	14	17
5	200	INPUT MECH. POWER (KW)	99.7	152.16	223	*
		OUTPUT MECH. TORQUE (Nm)	4570.2	6835.2	9717.3	*
		INPUT THERMAL POWER (KW)	70	100	154	*
		OUTPUT THERMAL TORQUE (Nm)	3208.8	4449.8	6710	*
7.5	133	INPUT MECH. POWER (KW)	72.4	110	152	*
		OUTPUT MECH. TORQUE (Nm)	4927.6	7361.4	9834.5	*
		INPUT THERMAL POWER (KW)	57	80	132	*
		OUTPUT THERMAL TORQUE (Nm)	3879.5	5353.3	8534.7	*
10	100	INPUT MECH. POWER (KW)	51	92	134	268
		OUTPUT MECH. TORQUE (Nm)	4480.9	8187.4	11301.1	24310
		INPUT THERMAL POWER (KW)	49	70	111	160.5
		OUTPUT THERMAL TORQUE (Nm)	4305.1	6229.3	9358.7	3 14101.5
15	66.7	INPUT MECH. POWER (KW)	45	68	125	220
		OUTPUT MECH. TORQUE (Nm)	5863.2	8882.9	15627.3	28979.3
		INPUT THERMAL POWER (KW)	41	60	96.6	139.3
		OUTPUT THERMAL TORQUE (Nm)	5342.0	7838.2	12076	18349.2
20	50	INPUT MECH. POWER (KW)	42	62	102	209.3
		OUTPUT MECH. TORQUE (Nm)	7139.6	10565.4	16628	35528
		INPUT THERMAL POWER (KW)	33	49	83.5	132
		OUTPUT THERMAL TORQUE (Nm)	5609.7	8358.1	13298.4	21430.2
25	40	INPUT MECH. POWER (KW)	33	53	80	128
		OUTPUT MECH. TORQUE (Nm)	6775.7	11124.5	15921.6	27198
		INPUT THERMAL POWER (KW)	28	40	67	89
		OUTPUT THERMAL TORQUE (Nm)	5749.1	8529.8	13361.22	189114
30	33.4	INPUT MECH. POWER (KW)	30	48	72.7	120
		OUTPUT MECH. TORQUE (Nm)	7399.1	11883.8	17180.7	30973
		INPUT THERMAL POWER (KW)	24	35	58	80
		OUTPUT THERMAL TORQUE (Nm)	5919.3	8665.2	13704.6	20419
40	25	INPUT MECH. POWER (KW)	26	42	60.2	80
		OUTPUT MECH. TORQUE (Nm)	8442.2	13380.8	18953	26281.6
		INPUT THERMAL POWER (KW)	18.5	30.5	36	62
		OUTPUT THERMAL TORQUE (Nm)	6007.0	9714.8	12135	20368.2
50	20	INPUT MECH. POWER (KW)	20.8	36	49	78
		OUTPUT MECH. TORQUE (Nm)	8243.6	13488.7	19280.5	31285.8
		INPUT THERMAL POWER (KW)	16	24	34.5	60
		OUTPUT THERMAL TORQUE (Nm)	6341.2	8986	13737	23779.5
60	16.7	INPUT MECH. POWER (KW)	17.5	30	39	72
		OUTPUT MECH. TORQUE (Nm)	8006.0	13292.5	18600	34174
		INPUT THERMAL POWER (KW)	13	22	25.8	50
		OUTPUT THERMAL TORQUE (Nm)	5947.3	9751.1	12301.7	23446
70	14.3	INPUT MECH. POWER (KW)	14.5	32	34	62
		OUTPUT MECH. TORQUE (Nm)	7262.7	11207	17819.8	33538.5
		INPUT THERMAL POWER (KW)	12	19	21.6	43
		OUTPUT THERMAL TORQUE (Nm)	6010.5	93352	12027	23260.6

- The Ratings are based on service factor of 1, continuously transmitted for 12 hours/day with normal overload of 100% momentarily for 15 seconds, 40% for 30 minutes, 25% for 2 hours.
- For Ratings at other Input speed please consult ELECON.
- For rating marked * consult ELECON

ACTUAL GEAR RATIO

SIZE OF UNIT	NOMINAL RATIO										
	5	7.5	10	15	20	25	30	40	50	60	70
10	4.74	7.17	9.5	14.33	19.5	24.5	29.5	40	50	60	70
12	4.9	7.43	9.8	14.67	20.5	24.5	29.5	40	50	60	70
14	5.1	7.57	9.8	14.67	20.33	24.5	30.5	39	49	61	69
17	5.1	7.37	9.83	14.75	19.66	25.5	29.5	40	49	60	71

OVERHUNG LOADS :

Whenever a sprocket, gear, sheave or pulley is mounted on the output shaft, a calculation should be made to determine the overhung load in Newtons on the shaft, using the formula :

$$P = \frac{KW \times 9550 \times K}{N \times R}$$

Where, P = equivalent overhung load in Newtons
 KW = power carried by shaft in Kilo Watts
 N = r.p.m. of the shaft
 R = pitch radius of sprocket, pinion, sheave or pulley in meter
 K = factor

Overhung Member K Factor

Sprocket	1.00
Spur Pinion	1.25
V-belt Sheave	1.50
Flat Belt Pulley	2.00

The calculated equivalent overhung load should be compared with the permissible values given in the table.

Maximum permissible overhung loads (Newtons) at centre of wheel shaft extension at 1500 r.p.m. Input Speed.

RATIO	BEARING NEAR SHAFT EXTENTION	SIZE OF UNIT			
		10	12	14	17
5	STD TRB	19550	22310	34654	
	STD TRB+CRB	29800	34650	50000	
7.5	STD TRB	21000	27000	40500	
	STD TRB+CRB	32000	36650	54975	
10	STD TRB	31000	32909	49363	55000
	STD TRB+CRB	33000	46636	69954	99000
15	STD TRB	28000	33050	50875	63594
	STD TRB+CRB	40000	55120	87089	130633
20	STD TRB	26700	33000	52080	65100
	STD TRB+CRB	42000	57674*	92000*	138000*
25	STD TRB	28000	32636	65270	78824
	STD TRB+CRB	47700	57004*	117068*	151025*

RATIO	BEARING NEAR SHAFT EXTENTION	SIZE OF UNIT			
		10	12	14	17
30	STD TRB	29000	32800	67980	81576
	STD TRB+CRB	51000	57800*	127545*	172185*
40	STD TRB	29000	31325	76726	88071
	STD TRB+CRB	50450	63272*	140745*	182968*
50	STD TRB	31000	32080	83450	100148
	STD TRB+CRB	52700	63305*	154935*	185922*
60	STD TRB	30000	34650	85535	102642
	STD TRB+CRB	53000	67630*	138050*	179465*
70	STD TRB	26000	41580	86310	103572
	STD TRB+CRB	56045	70950*	143484*	186530*

* SPECIAL HEAT - TREATED SHAFT IS SUPPLIED

TRB = TAPER ROLLER BEARING
 CRB = CYLINDRICAL ROLLER BEARING

APPROX WEIGHT AND OIL CAPACITY

		10	12	14	17
SFU	Net Weight (kgs.)	450	580	885	1260
	Gross Weight (kgs.)	595	900	1140	1700
	Oil Capacity (ltrs.)	20	25	36	60
SFO	Net Weight (kgs.)	480	660	940	1380
	Gross Weight (kgs.)	610	920	1180	1800
	Oil Capacity (ltrs.)	22	27	38	95

		10	12	14	17	
SFV	Net Weight (kgs.)	440	660	870	1575	
	Gross Weight (kgs.)	560	845	1120	2000	
	Oil Capacity (ltrs.)	20	29	43	106	
SSM	Net Weight (kgs.)	-	780	1280	-	
	Gross Weight (kgs.)	-	940	1540	-	
	Approx. Oil Capacity in ltrs. For Diff. Mounting Positions	A	-	24	28	-
		B	-	22	25	-
		C	-	26	28	-
D/E		-	23	30	-	

RECOMMENDED LUBRICANT

Brands	Grade
Bharat Petroleum	Cabol 320
Castrol	Alpha Zn 320 or Alpha Sp-320 or Tribol 1100/320 TGQA
Hindustan Petroleum	Enklo 320 or Parthan EP 320
Indian Oil	Servomesh SP 320 or Servosystem 320

RECOMMENDED GREASE

BRAND	GRADE
Castrol	EPL 2
Indian Oil	Servogem EP 2

PRODUCT SAFETY INFORMATION

General ELECON gear units will operate safely provided that they are selected, installed, used and maintained properly. As with any equipment consists of rotating shafts and transmitting power, adequate guarding is necessary to eliminate the possibility of physical contact with rotating shafts or coupling.

Potential Hazards The following points should be noted and brought to attention to the persons involved in the installation, use and maintenance of equipment.

1. For lifting of gearunit eye-bolts or lifting points (on larger units) should be used.
2. Check the grade and quantity of lubrication before commissioning. Read and carry out all instructions on lubricant plate and in the installation and maintenance manual literature.
3. Installation must be performed in accordance with the manufacturer's instruction and be undertaken by suitably qualified personnel.
4. Ensure the proper maintenance of gearboxes in operation. **USE ONLY ELECON SPARES FOR GEARBOXES.**
5. The oil level should be examined periodically, if required the oil should be filled again.
6. The operating speeds, transmitting powers, generated torques or the external loads must not exceed the design values.
7. The driving and the driven equipment must be correctly selected to ensure that the complete installation of the machinery will perform satisfactorily e.g. avoiding system critical speeds, system torsional vibration etc.

Any other required information or clarification can be obtained by writing to :

ELECON ENGINEERING CO. LTD.

POST BOX # 6, VALLABH VIDYANAGAR 388 120, GUJARAT, INDIA

TEL.: +91-2692-236513, 236520, 232890 FAX : +91-2692-236527

E-MAIL : infogear@elecon.com

Web Site : <http://www.elecon.com>

As improvement in designing are continuously being made, the details and dimensions are subject to alteration without notice.